

# Cilindros D.E. brida trasera [Serie 8100]

Bottom-bridle D.A. Cylinders [Series 8100] / Vérins à D.E. avec bride arrière [Série 8100]

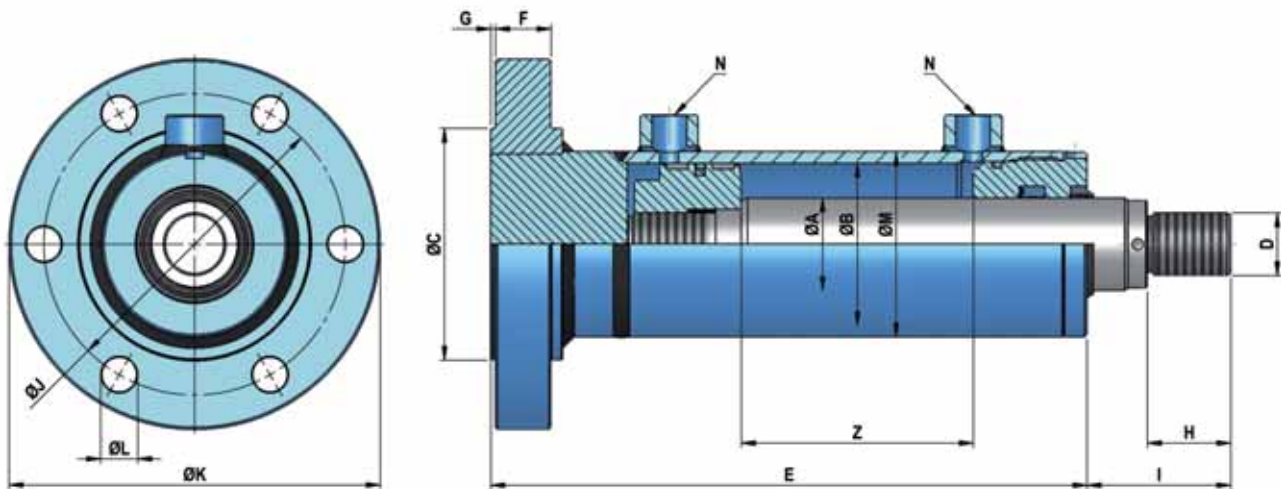

REF.	Ø A	Ø B	E	C	D	F	G	H	I	J	K	L	M	N BSP
8100/Z	20	32	125 + Z	52	M14x1,5	15	2	18	35	67	80	7	42	1/4
8101/Z	22	40	130 + Z	60	M16x1,5	15	2	22	40	82	100	9	50	3/8
8102/Z	25													
8103/Z	28	50	139 + Z	75	M20x1,5	18	2	28	48	103	125	11	60	3/8
8104/Z	25													
8105/Z	28													
8106/Z	30													
8107/Z	36	60	149 + Z	90	M27x2	20	2	36	58	120	145	13	70	3/8
8108/Z	30													
8109/Z	35													
8110/Z	40	63	149 + Z	90	M27x2	20	2	36	58	120	145	13	75	3/8
8111/Z	36													
8112/Z	40													
8113/Z	45													
8114/Z	35	70	157 + Z	100	M27x2	24	2	36	58	130	160	15	85	3/8
8115/Z	40													
8116/Z	45													
8117/Z	36	80	171 + Z	110	M33x2	28	2	45	68	142	170	15	95	3/8
8118/Z	40													
8119/Z	45													
8120/Z	50													
8121/Z	56													
8122/Z	45	100	185 + Z	135	M42x2	30	3	56	85	170	202	17	115	1/2
8123/Z	50													
8124/Z	56													
8125/Z	60													
8126/Z	70	125	260 + Z	170	M48x2	40	3	63	92	210	250	21	145	3/4
8127/Z	70													
8128/Z	90	140	273 + Z	190	M64x3	40	3	85	120	230	280	21	160	3/4
8129/Z	80													
8130/Z	90													
8131/Z	110	160	308 + Z	215	M80x3	54	3	95	130	270	320	29	180	1
8132/Z	110													
8132/Z	110	200	363 + Z	270	M80x3	65	3	95	130	330	385	32	230	1

Z = carrera (a definir por el cliente). Consultar amarres de vástago en la página 39.

Z = stroke (to be defined by customer). Check rod attachments on page 39.

Z = course (à définir par le client). Vérifiez les fixations de tige sur page 39.

03



La fuerza de un equipo a tu servicio

www.cicrosa.com • info@cicrosa.com • Tel [+34] 979 761 434

[ 25 ]